

A REAL ESTATE AGENT'S GUIDE TO



SOLD

NORA[™]
NATIONAL OILHEAT RESEARCH ALLIANCE



American
Energy Coalition

www.AmericanEnergyCoalition.org

**SELLING OIL
HEATED HOMES**



The more you know, the more you'll sell



Today's consumers are savvier and more connected than ever. As a result, today's real estate agents are faced with many different questions from clients about Oilheat.

This guide will teach you the facts about Oilheat so that you'll be able to serve your clients better. By eliminating unnecessary concerns for potential buyers and

sellers of Oilheated homes, you'll improve your closing ratio and create more impressive listings.

If, after reading this guide, you still have questions about Oilheat, please do not hesitate to contact a local Oilheat dealer. Oilheat dealers understand how hard you work to meet your clients' needs and can be a valued resource for information and assistance.

Five fast facts about Oilheat

1. There are approximately 7 million Oilheated homes in the U.S.; 300,000 Oilheated homes were built during the past decade alone.
2. The efficiency levels of Oilheat systems can exceed 95% (see page 3).
3. Today's home is heated with Bioheat® fuel, a blend of ultra-low sulfur heating oil and renewable biodiesel, making it cleaner than ever (see pages 3 and 4).
4. For every gallon of oil burned, 120,000-140,000 BTUs are generated (see page 5).
5. Many Oilheat companies offer 24/7 emergency service and preventive maintenance to ensure heating equipment performance in harsh weather conditions (see page 14).

New advances raise efficiency and lower consumer costs

Q: Is Oilheat an efficient way to heat the home?

A: Yes, Oilheat has always provided efficient and affordable warmth, and it's gotten even better in recent years. Most of today's oil-fired systems display the U.S. Department of Energy's ENERGY STAR® label, which signifies that they are technologically advanced and clean-burning, with near-zero emissions levels. Some Oilheat systems have efficiency ratings that exceed 95%, and all Oilheat systems are compatible with clean, green Bioheat® fuel.



Q: What is Bioheat® fuel?

A: Bioheat® fuel is the evolution of Oilheat. It's a blend of conventional Oilheat with biodiesel, a renewable energy resource made domestically from soybean oil and other natural sources. Bioheat® fuel typically consists of 2%-20% biodiesel; blends with a 2% biodiesel content are referred to as B2, blends with a 5% biodiesel content are referred to as B5.





Cleaner Than Ever

Q: Some clients may be concerned that Oilheat isn't clean. What's the truth?

A: Just like old cars, older heating systems produced undesirable levels of combustion emissions. But today's Oilheat technology has been tested by the U.S. Department of Energy's Brookhaven National Laboratory and found to emit virtually no smoke. That's because today's Oilheat systems can **achieve annual fuel utilization efficiency (AFUE) ratings of 95% or higher.** And even with old systems, annual tune-ups and preventive maintenance can reduce emissions and improve equipment efficiency.



Sometimes people see dark spots or streaks on the walls of Oilheated homes and erroneously assume they are caused by soot from the heating system. These marks are typically created by common household dust that has been "baked on" walls and other surfaces near vents, radiators or baseboards. To prevent these streaks and spots, advise your client to dust around baseboards, vents or radiators, especially during the heating season.

Looking at Fuel Prices

Q: Is heating oil a good value?

A: Yes, heating oil is a commodity traded on the open market, so you can expect occasional blips — both up and down — in the price. Heating power is typically measured in British thermal units or BTUs, and for every gallon of oil burned, 120,000–140,000 BTUs are generated. That's more than enough to keep you comfortable in the coldest winters.

Competition among local Oilheat companies plays a big role in giving homeowners more choices and better value.

Also, the United States continues to produce more and more crude oil while cutting imports. In addition, biodiesel production continues to grow, creating even more supply for homeowners. Furthermore, as Oilheat system technology continues to improve, less and less fuel is required to provide more and more heat.



Abundant supplies

Q: Should homeowners be concerned about heating oil supplies?

A: Not at all — the United States has a Strategic Petroleum Reserve with a capacity of 727 million barrels, the world's largest emergency oil stockpile. The country also maintains a one-million barrel heating oil reserve. There are over 50 oil-producing countries in the world, and the U.S. is not dependent on any one country or region for its heating oil supply. Thanks to advancements in drilling technology and increased production from shale and other tight rock formations in North Dakota and Texas, U.S. domestic crude oil production has reached its highest levels in decades.

Q: Where in the world does our oil come from?

A: According to the U.S. Energy Information Administration, in October 2013, for the first time since 1995, the U.S. produced more crude oil than it imported. The top five oil-producing states, measured by thousands of barrels per day, for the month of September 2016.

- **Texas** (3,163)
- **North Dakota** (962)
- **California** (511)
- **Alaska** (452)
- **Oklahoma** (415)



Crude Oil Imports Top 10 Countries, Sept. 2016

(According to the U.S. Energy Information Administration)

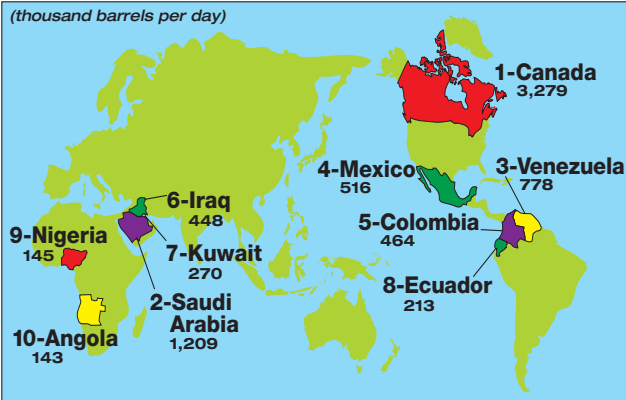

Selling Points



- *The U.S. is one of the world's leading oil producers*
- *The U.S. produces more crude oil than it imports*
- *Domestic oil production is expected to continue rising for the foreseeable future*
- *Thanks to ultra-low sulfur and Bioheat® blends, home heating oil is cleaner than ever*
- *Bioheat® fuel is produced in America using domestic feedstocks*
- *The abundance of locally owned full-service dealers means Oilheat customers are free to choose the supplier whose pricing, services and programs they are most comfortable with*



... and easy deliveries

Q: What's the easiest way for a homeowner to get a delivery?

A: The easiest way to get heating oil is through automatic delivery. The Oilheat company watches daily temperatures to keep track of how cold the weather has been and calculates an individual burn rate for each customer. This lets the company know just when a customer will need a delivery, long before most people would know it themselves.

Automatic delivery provides peace of mind, because the homeowner doesn't have to think twice about how much fuel is in the tank.

How Does an Oilheat System Work?

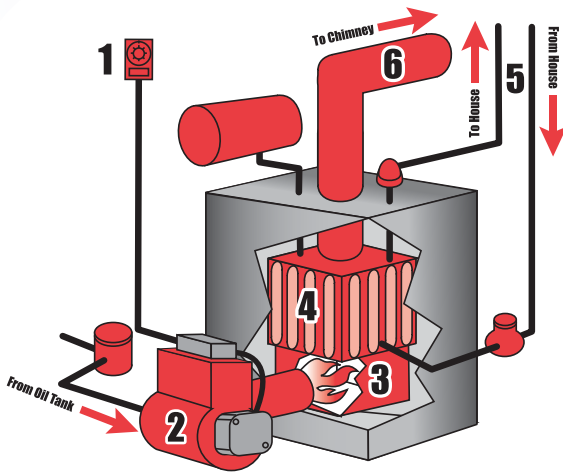

Hot Water System

- 1** Your thermostat senses that the room's temperature has fallen below the designated setting. In response, it sends a signal to the controls on the oil burner.
- 2** Oil is then pumped to the burner. The nozzle on the burner converts the oil into a fine mist, which is then sent to the combustion chamber.
- 3** Inside the combustion chamber, the fine mist is mixed with air and ignited, which causes the chamber to get extremely hot.
- 4** Water is heated as it circulates around the combustion chamber, and is then pumped throughout the baseboard heaters of the home. This results in warmth issuing from the baseboard heaters.
- 5** As the water circulates and begins to cool, it cycles back to the boiler and is heated again and again, until the designated thermostat temperature is maintained.*
- 6** Combustion emissions from the burner are sent through the flue pipe and out the chimney, leaving the home altogether.

**Note: In a steam system, steam is generated instead of hot water. The steam rises to the radiators and automatically circulates. If water levels drop, there is an automatic low water cutoff to protect the boiler.*

The information contained in these two pages is a great reference tool for you, as well as your clients. Individual systems may vary from the pictures presented below, but the underlying concepts will always remain the same.

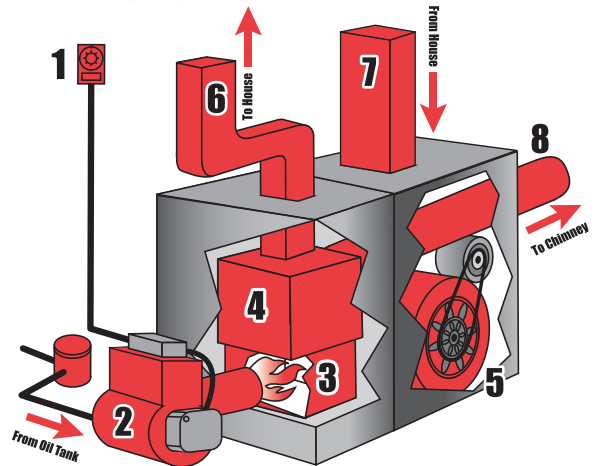

Hot Air System

- 1** Your thermostat senses that the room's temperature has fallen below the designated setting. In response, it sends a signal to the controls on the oil burner.
- 2** Oil is then pumped to the burner. The nozzle on the burner converts the oil into a fine mist, which is then sent to the combustion chamber.
- 3,4** Inside the combustion chamber, the fine mist is mixed with air and then ignited, which causes the chamber to get extremely hot.
- 5,6,7** The furnace's heat exchanger warms the air from the house. This warm air is then propelled by a blower through the home's ducts.
- 8** Combustion emissions from the system are sent through the flue pipe and out the chimney, leaving the home altogether. None of this air enters the house.

Upgrading to a lean, clean modern machine

Q: What if a buyer is faced with an old system?

A: An old Oilheat system is no different than any other outdated system, regardless of the fuel used. Old systems can generate high fuel bills but can easily be replaced with new Oilheat technology. The Consumer Energy Council of America concluded that changing fuel sources makes “no economic sense” and a better investment would be to upgrade older equipment in order to improve efficiency.

Upgrading to a new Oilheat system pays

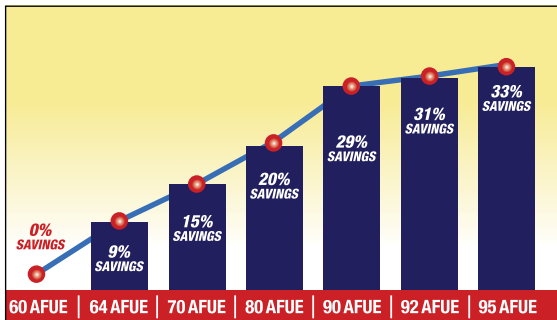

Q: How does a homeowner know if a system should be replaced?

A: Oilheat systems typically last 30 years and longer. However, the older and less efficient the system, the greater the gain in efficiency and cleanliness through upgrading. Many Oilheat dealers perform low or no-cost equipment evaluations that will help determine if a heating system needs to be replaced.



Size Matters

Modern Oilheat systems are smaller, cleaner and more efficient than ever.

Q: Besides a total replacement, are there low-cost ways to improve an Oilheat system's efficiency?

A: Yes. A professional tune-up once a year can increase efficiency by as much as 10%. Homeowners can also improve efficiency – by as much as 25% – if they replace an old burner with a modern, flame-retention burner rather than the entire furnace or boiler. This is a modest investment with a rapid payback. It is estimated that flame-retention burners have saved homeowners millions of dollars in fuel costs and conserved more than six billion gallons of oil.

Oilheat gives you all the hot water you need

Oilheat is a great way to heat water. This is a strong selling point for growing families whose dishwashers, washing machines and showers always seem to be running. With the rapid recovery rates of oil-fired water heaters, it's unlikely that homeowners will run out of hot water – and they'll save money, too! Homeowners should contact a local Oilheat company to find out which water heating option is best for them.

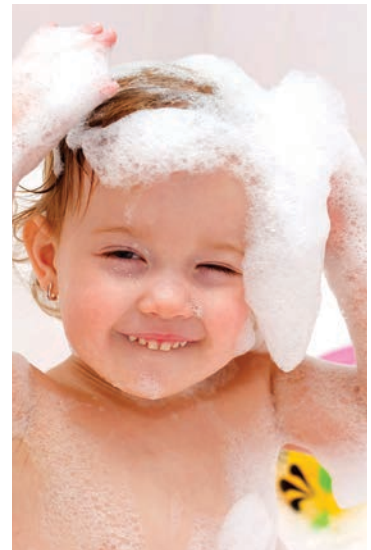

The Truth About Tanks

“I love the house, but what about the oil tank?”

There are lots of misconceptions about oil tanks. Tanks can last for decades without needing replacement. When the time comes for replacement, there are many new options that can benefit the homeowner.

- With an oil storage tank on the property, the homeowner always has supply on hand.
- With a tank, homeowners pay for the fuel they are delivered – no estimates, no questions.
- Advances in technology have resulted in the manufacture of tanks made from corrosion-resistant materials. When properly installed and maintained, today’s average oil tank can last for many decades.

If you have more questions, call a local Oilheat company that will be able to address any concerns you or your client may have.



Customized storage solutions

Several options are available if a homeowner plans to renovate and wants to save space.

- Today’s aboveground tanks are relatively small (275 gallons) and they can be customized for hard-to-fit places. For example, a vertical tank can be installed in small or unusual-shaped spaces in a basement or garage. Tanks can also be installed outside the home and hidden in a tank enclosure, like the one pictured above.
- A homeowner can also replace an old buried tank with a modern one. These new units are guaranteed to be corrosion resistant. If replacing an underground tank, your client should contact a local Oilheat company for the best options.

Selling Point



An oil tank on the property puts your clients in control of their comfort. The storage tank allows the Oilheat user to have an adequate supply of heating oil ready for use with the arrival of cold weather. Many Oilheat dealers offer the option of automatic delivery. By tracking the weather and each customer’s fuel consumption, they can refill the tank before the fuel level gets too low. The customer never needs to think about it.

Two Easy Sells: Service and Safety

Oilheat companies pride themselves on delivering peace of mind and responsive service. Remind your clients that:

- Many Oilheat dealers offer 24/7 emergency service.
- Oilheat users gave their oil companies an average rating of 94% for friendly and fast service in a recent national survey.



- Oilheat companies aren't large monopolies, so homeowners can choose a company that best suits their needs and personalities. Most Oilheat dealers are locally owned and operated with deep roots in their communities.
- Heating oil cannot explode. If you dropped a lit match into a barrel of heating oil, the match would go out as if you dropped it in water. Oil must be turned into a fine-particle mist before it will ignite and burn, typically at a temperature of 130°-140°.



Tips for your clients

- Advise your client not to wait until it's cold before arranging for service from an Oilheat company.
- Encourage your client to take advantage of Oilheat's versatility. Home heating oil is now used in radiant floor heating systems, to warm pools and spas, and even to melt snow from driveways.
- If your clients plan to add a room or renovate, their local Oilheat company may know about options that a typical contractor is not familiar with.
- Let your clients know that most heating oil companies offer monthly payment plans, which can make budgeting heating expenses a snap.
- Recommend that your clients have their heating systems serviced regularly to conserve fuel and prevent breakdowns. Homeowners can get the most convenient appointments if they schedule service during the off-peak periods of spring and summer.



How A Full Service Oilheat Company Can Help You

Having a relationship with an Oilheat company can help you in many ways. The right dealer will:

- Offer training and information on heating systems and regulations.
- Help you solve problems that could delay a closing.
- Service REO properties.
- Provide tips to help you list and sell Oilheated homes.
- Analyze a home's oil bills and its consumption history.
- Provide a statement of condition on a home's heating system and an analysis of its service history.
- Measure the oil level in the storage tank.
- Transfer service agreements on a home's heating equipment and fuel tank to the new owner at closing.
- Clean and tune up the heating system before the home is shown. Reach out and work with Oilheat dealers as partners. You will be surprised at how accommodating they can be.



NORA
NATIONAL OILHEAT RESEARCH ALLIANCE

American
Energy Coalition

www.AmericanEnergyCoalition.org



© 2017 American Energy Coalition
© 2017 NORA